

16.0 Measurement, Accounting and Reporting Plan

The Measurement, Accounting and Reporting Plan (MARF) will be prepared in accordance with Energy Resources Conservation Board Directive 042, and submitted separately from this application. The MARF will provide details on how fluids will be measured and reported. Figure 16-1 shows the production battery at the central processing facility (CPF) and Figure 16-2 shows the injection facility. Reporting measurement points for both are as follows.

Production battery:

- Bitumen production – individual well production will be determined using test separator flow rates and water cuts. The sum of bitumen volumes from all wells will be prorated to the plant production on a daily basis. Total plant production will be metered downstream of the bitumen tanks, compensating for inventory with level measurement in the tanks and diluent addition, which will also be metered.
- Produced water production – individual well production will be determined using test separator flow rates and water cuts. The sum of produced water volumes from all wells will be prorated to the total de-oiled produced water, including condensed water vapour.
- Produced gas – total produced gas will be measured and the average gas-to-oil ratio (GOR) will be calculated on a monthly basis. The GOR will be used to determine produced gas volumes for the individual wells.
- Fuel gas/produced gas – fuel gas and produced gas to boilers will be measured and all other streams, such as purge gas to flares and lift gas, will also be measured.
- Fresh water – makeup water volumes will be measured at the individual wells and at the plant inlet; a small portion will be used as utility water.

Injection facility:

- Steam injection – individual steam injection rates will be measured at each wellhead. These rates will be prorated back to the total high pressure (HP) steam measured off the HP steam separators. This is done to compensate for any loss in quality from the steam separators to the wellheads. Total HP steam can also be calculated by total boiler feedwater (BFW) – blowdown; both streams will be measured.
- Disposal – volumes will be determined by a meter downstream of the disposal tank. The volumes will also be measured at the individual disposal wells.
- Vent/evaporation – all vent/evaporation calculations will be included in the MARF.

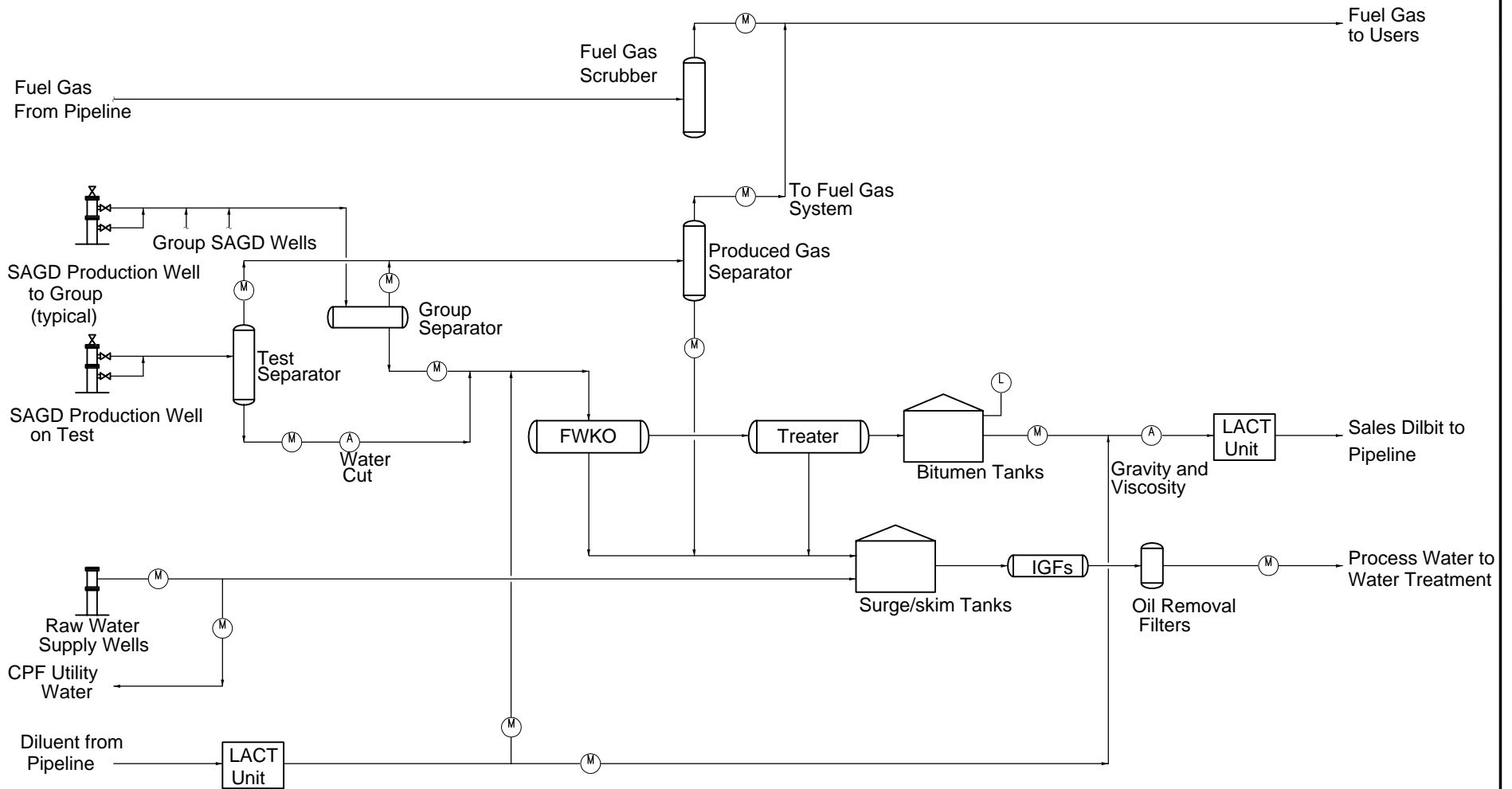

Drawn By:
TLI
Date:
2010-02-16

Legend:
A analyzer
CPF central processing facility
FWKO free water knockout
HP high pressure
IGF induced gas flotation

L level
LACT lease automated custody transfer
LP low pressure
M meter
SAGD steam-assisted gravity drainage



Figure 16-1
Production Battery
Metering Schematic

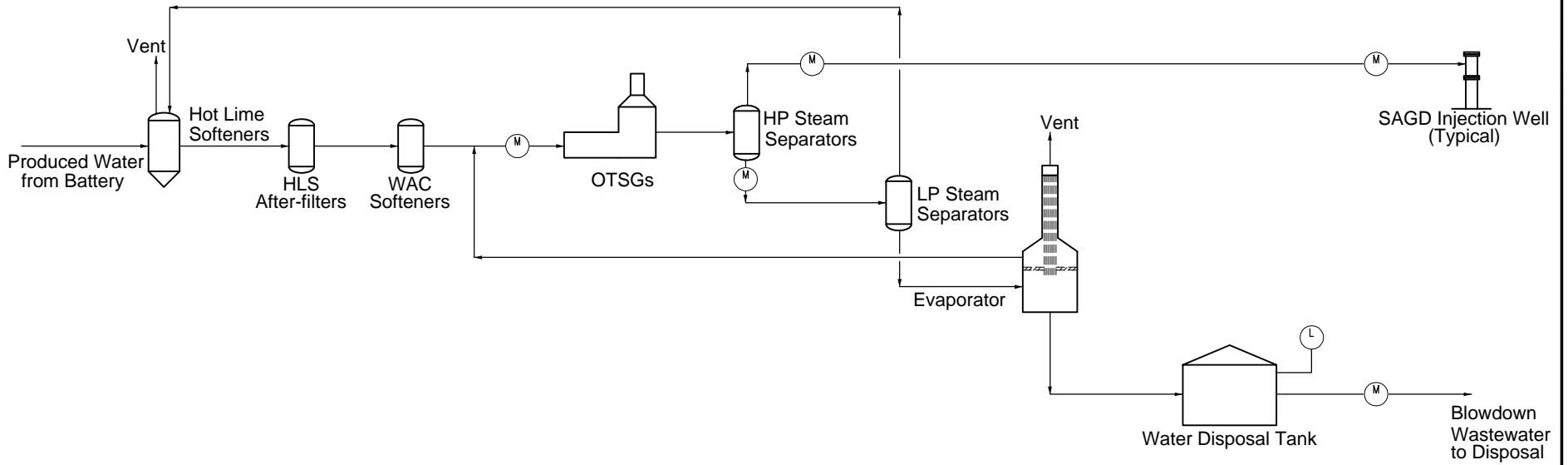

Drawn By:
Date:
2010-02-19

Legend:

HLS hot lime softener
HP high pressure
L level
LP low pressure

M meter
OTSG once-through steam generator
SAGD steam-assisted gravity drainage
WAC weak acid cation



Figure 16-2
Injection Facility
Metering Schematic

The MARP will also include the following major sections:

- proposed operating procedures
- meter/gauge calibration and proving – description of process and frequency
- group/test operations
- S&W procedures including frequency and method
- water cut measurement – description of meter and accuracy
- volume measurement/proration – including methodology and test criteria
- accounting calculations and reporting
- estimated production worksheet – description of proration calculations for bitumen, gas and water production for each well
- accounting formulas – all calculations used to determine and report bitumen/gas/water production, diluent, raw water and produced/flared gas
- sample production accounting reports for the CPF